

Argo
8x8 Avenger



ARGO

AVENGER

PARTS MANUAL

From Serial # ...23216

Foreword

ODG has prepared this parts manual for the AVENGER model to assist both qualified mechanics and vehicle owners in ordering correct, quality replacement ARGO parts.

Proper and regular service, and replacing old, worn or broken parts with the correct ARGO replacement parts, are both essential to prolonging the life of the ARGO. Please refer to this parts manual before ordering any replacement part.

All information contained in this AVENGER Parts Manual is based on the latest product specification available at time of printing. If your AVENGER differs from the specifications contained in this manual, contact Ontario Drive & Gear Limited for information.

ODG reserves the right to alter specifications on the AVENGER model at any time, without obligation or prior notification.

Reproduction of this AVENGER Parts Manual, in whole or in part, is prohibited without prior written permission from Ontario Drive & Gear Limited.

Vehicle Identification

AVENGER - Serial Nos. V23216

Explanation of Parts Manual Format

- Ref** - Reference number between assembly diagram and component parts list
- Part No.** - Argo replacement part number for identification and re-ordering
- Description** - Part description for identification and re-ordering
- Qty** - Indicates the quantity of a part used in an assembly



Using the Parts Manual

1. Find the major vehicle assembly in the Table of Contents on this page, and turn to that section.
2. Locate the part in the illustration that you wish to order.
3. Refer to the parts list in that section.
4. Find the correct part number (Part No.), part description (Description) and correct quantity (Qty).
5. Use *only* this information to order ARGO replacement parts. *DO NOT* attempt to order a replacement part by reference number or page number.

Table of Contents

Foreword	i
Vehicle Identification	i
Using the Parts Manual	ii
1.0 Transmission	1
2.0 Intake and Exhaust System	3
3.0 Clutch System	5
4.0 Power Pack Assembly	7
5.0 Steering & Brake System	9
6.0 CE Kit - 850-70 (Opt.)	11
7.0 Vehicle Body & Firewall	13
8.0 Frame & Drive System	15
9.0 Fuel System & Seat Assembly	17
10.0 Electrical System	19

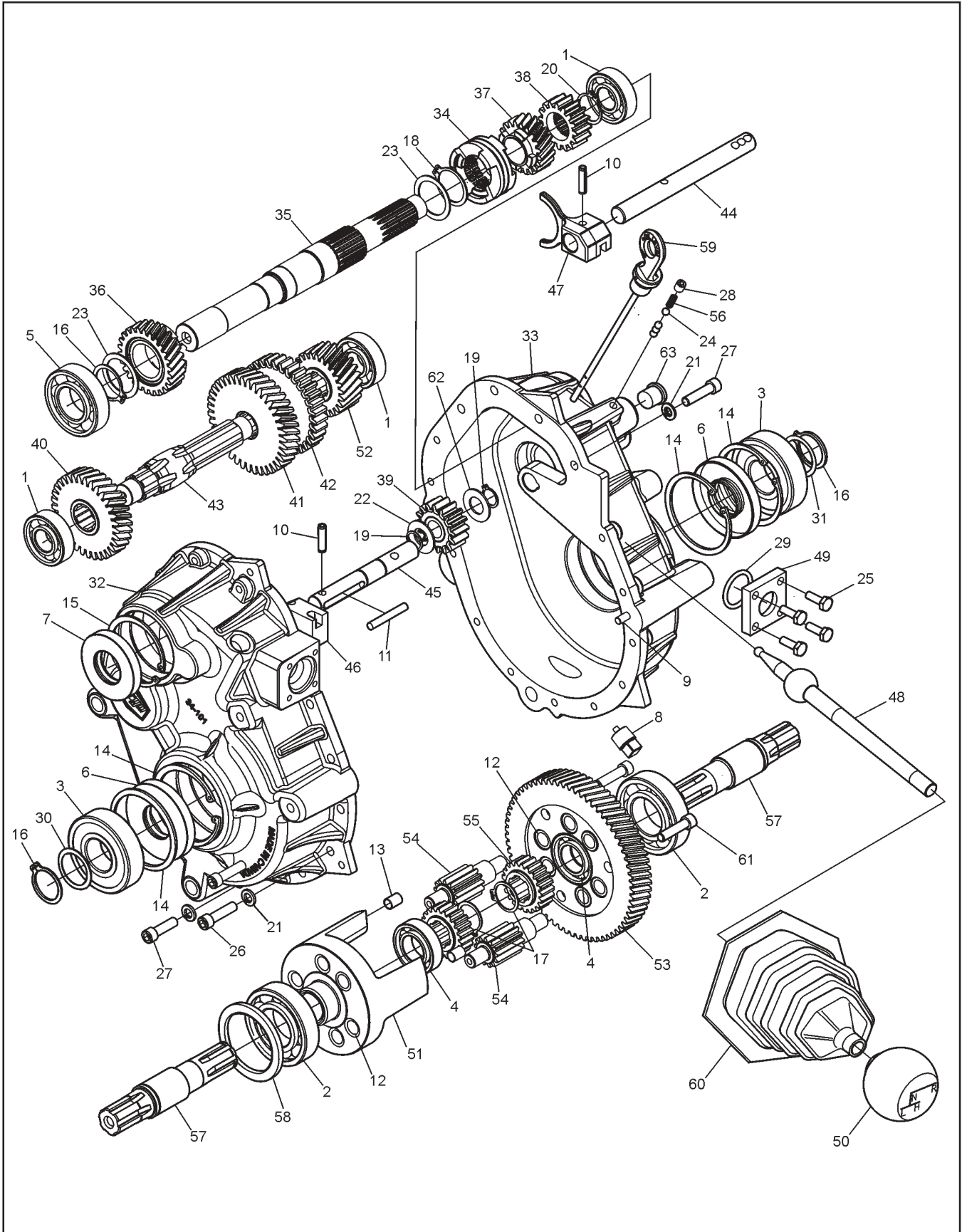

Avenger Parts Manual

1.0 Transmission

Ref.	Qty.	Part #	Description	Ref.	Qty.	Part #	Description
	1	34-100	Transmission Assembly	41	1	34-110	Gear, Helical - LOW 12DP 39T
1	3	101-01	Bearing, Ball 6204Z-C3				
2	2	101-03	Bearing, Ball 6207-C3	42	1	34-111	Gear, Reverse - 10DP 33T
3	2	101-05	Bearing, Ball 6306LLU-C3/2A	43	1	34-112	Shaft, Spline
4	2	101-15	Bearing, Ball 6005-C3	44	1	34-113	Shaft, Shift - Forward
5	1	101-16	Bearing, Ball 6206-C3	45	1	34-114	Shaft, Shift - Reverse
6	2	102-03	Seal,Oil WBS 30x72x10 NB D/LIP	46	1	34-115	Block, Shift
7	1	102-05	Seal,Oil WBS 30x62x10 NB D/LIP	47	1	34-116	Fork, Shift
8	1	103-02	Plug, Magnetic 3/8-18NPT SQ.HD	48	1	34-117	Lever, Shift
9	2	104-03	Pin, Dowel 1/4x7/8	49	1	34-118	Plate, Shifter
10	2	104-39	Pin, Spring - 1/4 x 1.0	50	1	34-121	Knob, Shift - w/Argo Logo
11	1	104-40	Pin, Dowel - 1/4 x 1.75	51	1	34-122	Cage, Differential
12	12	105-03	Bushing, Oilite - 1/2x3/4	52	1	34-123	Pinion, Helical - 25T
13	3	105-23	Bushing, Dowel - .312 x .5	53	1	34-124	Gear Plate - 66T
14	4	106-03	Retaining Ring HO-281PA	54	6	34-13	Gear, Planet - 12T
15	1	106-05	Retaining Ring HO-244-PA	55	2	34-14	Gear, Sun - 21T
16	3	107-02	Retaining Ring SH-0118-PA	56	2	34-32	Spring, Comp. 0.22x.50
17	2	107-04	Retaining Ring SH-0098-PA	57	2	34-98	Shaft, Output - Splined
18	1	107-10	Retaining Ring SH-0125-PA	58	1	114-01	Washer, Shim 2.25 x 2.81 x .02
19	2	107-11	Retaining Ring	59	1	CE-035	Dipstick - with Breather - 190mm
20	1	107-12	Retaining Ring SH-0100-PA	60	1	609-38	Boot, Shifter
21	15	108-05	Lockwasher 5/16 Split-Ring Zn	61	3	112-64	SHCS, 5/16-18 x 1.25
22	1	108-78	Washer, Thrust	62	1	108-81	Washer, Retaining Thrust
23	2	108-79	Washer, Thrust	63	1	113-14	Plug, Polyethylene - 5/8" Dia.
24	5	109-05	Ball, Steel 6mm 62-67 Rc				
25	4	112-04	HHCS 1/4-20x3/4 GR2 Zn				
26	13	112-143	SHCS 5/16 x 1.25 Zn				
27	2	112-144	SHCS 5/16 x 1.0 Zn				
28	1	112-145	SHSS 5/16 - 18 x 3/8				
29	1	113-11	O-Ring #AS568-216-70BN				
30	1	114-04	Washer, Shim 1.19x1.50x.04				
31	1	114-05	Washer, Shim 1.19x1.50x.02				
32	1	34-101	Housing, Transmission - L				
33	1	34-102	Housing, Transmission - R				
34	1	34-127	Clutch, Dog				
35	1	34-104	Shaft, Input - 19/15T Spline				
36	1	34-128	Pinion, Helical - HI 12DP 26T				
37	1	34-129	Pinion, Helical - LO 12DP 20T				
38	1	34-107	Pinion, Reverse - 10 DP 16T				
39	1	34-108	Gear, Idler - Rev - 10DP 16T				
40	1	34-109	Gear, Helical - HI 12DP 33T				

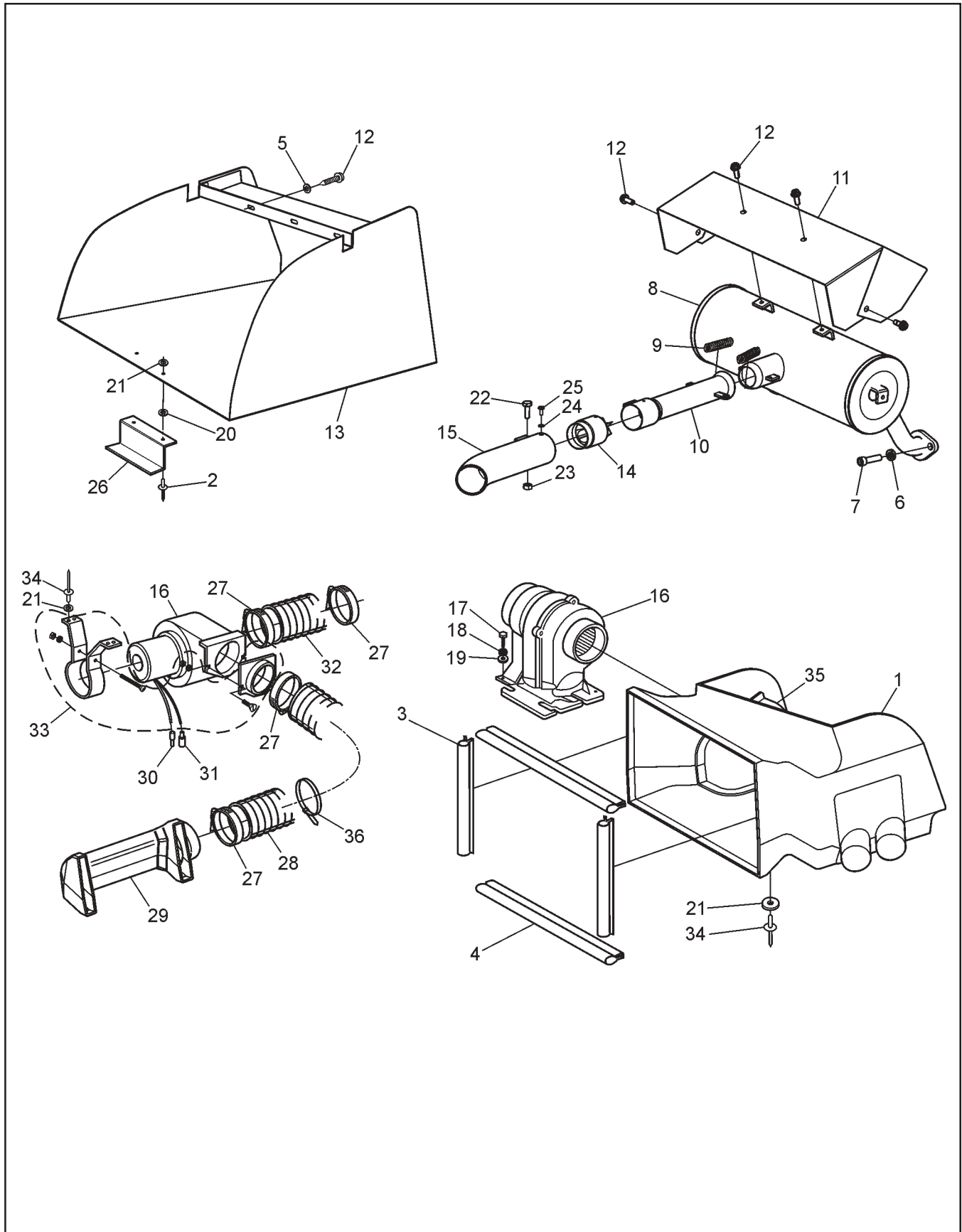

Ref.	Qty.	Part #	Description
1	1	809-03	Duct, Intake
2	2	120-13	Rivet, 3/16 x 5/8 - Black
3	2	809-05	Seal, Radiator - 10.25" LG
4	2	809-06	Seal, Radiator - 16.25" LG
5	3	108-01	Washer, Fender 1/4 BS x1.25 OD
6	4	108-05	Lockwasher 5/16 Split Ring Zn
7	4	117-73	Nut, M8x1.25 Zn
8	1	607-105	Muffler
9	2	126-57	Spring, Extension- 7/16x2.14
10	1	607-106	Pipe, Flared - Asm
11	1	807-85	Shield, Heat - Muffler
12	7	112-19	Screw, IHWH T/C Slot 1/4-20x1/2
13	1	607-109	Duct, Exhaust
14	1	607-103	Spark Arrester
15	1	607-107	Pipe, Tail - Asm
16	1	125-91	Blower Fan
17	4	103-47	HHCS, #10-24x1/2
18	4	120-05	Washer, .19x.50x.04
19	4	108-59	Lockwasher #10 Int. Tooth
20	2	125-58	Washer, Fibre - W-77F
21	15	120-04	Washer, .19 x .50 x .08 Zn
22	1	112-04	HHCS 1/4-20 x 3/4 Gr2 Zn
23	1	117-81	Locknut, 2-way 1/4-20 Zn
24	1	108-77	Lockwasher, #8 External Tooth
25	1	112-43	Screw IHWH #8 x 3/8
26	1	707-44	Support, Exhaust Duct - Avenger
27	4	125-35	Clamp, Gear 3.50" HF-52
28	1	127-139	Hose, Brake Fan Discharge
29	1	127-134	Duct, Brake Cooling
30	1	118-02	Terminal, Male #76-1251
31	1	118-03	Terminal, Female #76-1289
32	1	127-140	Hose, Brake Fan Inlet
33		125-92	Adpt. & Mounting Kit - includes the following:
	1		Mounting Bracket
	1		Nut, #10-32
	1		Lockwasher, 3/16"
	1		Screw, #10-32x2"
	2		Nut, 1/4-20
	2		Lockwasher, 1/4"
	2		Screw, 1/4-20x5/8"
	1		Adaptor, 3" dia.
34	13	120-09	Rivet, 3/16 x 1.0 Black
35	1	809-04	Shroud, Intake Duct
36	1	100-102	Tie Wrap, 14" - White

3.0 Clutch System

Avenger Parts Manual

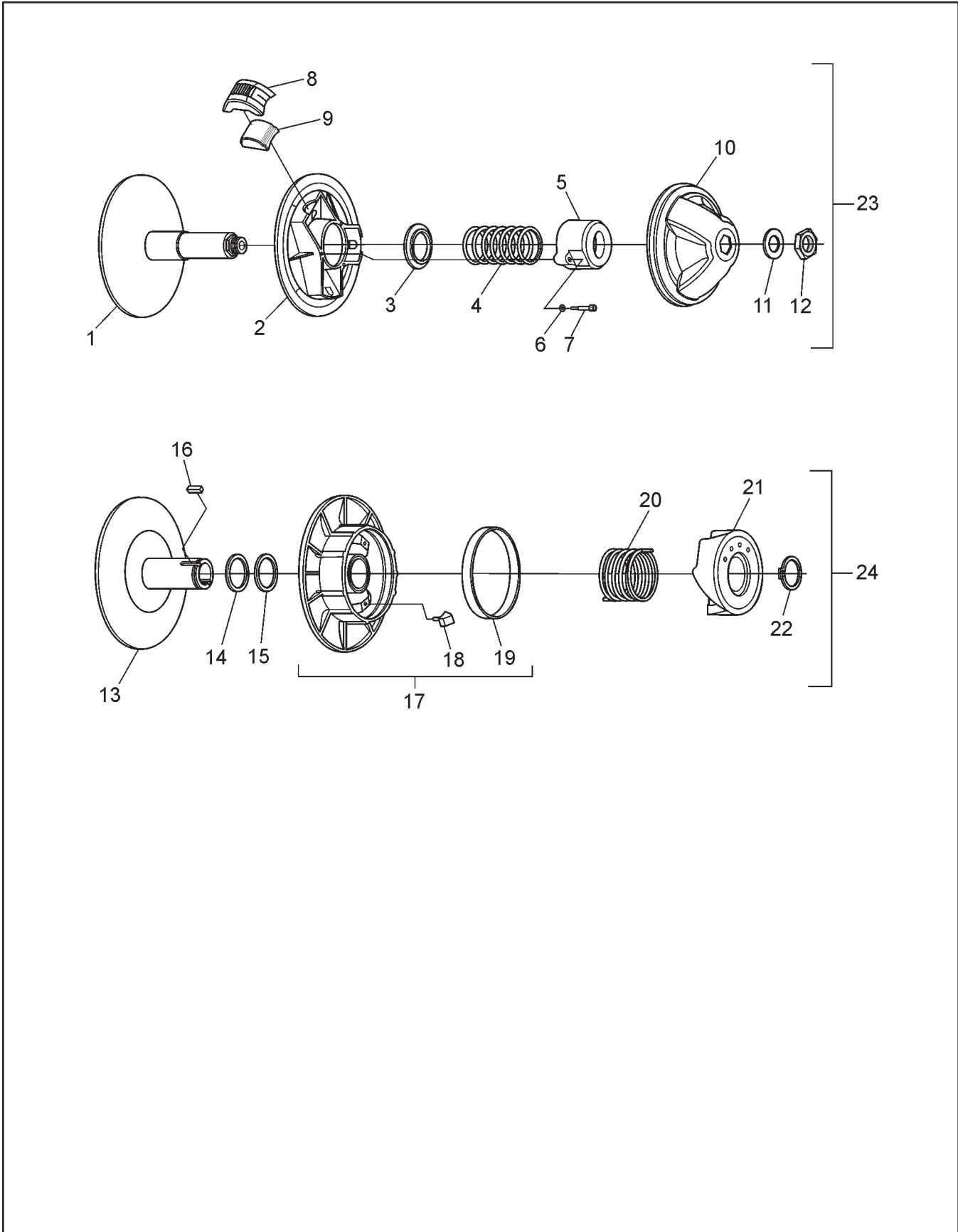

Ref.	Qty.	Part #	Description
1	1	0405-0075	Flange, Fixed
2	1	0410-0026	Flange, Sliding
3	1	0150-1014	Spring Guide Washer
4	1	0451-1114	Spring
5	1	0440-0005	Spring Cover
6	3	420-2453-700	Lockwasher
7	3	0080-0021	Screw, Cap
8	3	0130-3009	Block
9	3	0135-3065	Weight (275gr)
10	1	0115-3042	Cap
11	1	0080-0153	Washer, Zn
12	1	0080-0100	Nut
13	1	5105-0045	Flange, Fixed
14	1	ASA-1	Washer, Shim 1.2
15	as req	ASA-1-S	Washer, Shim 0.6
16	1	ASK-5	Key, Square
17	1	5110-0020	Flange, Sliding
18	3	ANS-2-T	Cam Shoe
19	1	5140-3006	Cam Bushing
20	1	5051-1110	Spring
21	1	5120-2043	Cam
22	1	371-9031-000	Retaining Ring, Outside
23	1	127-135	Clutch, Driver
24	1	127-136	Clutch, Driven

4.0 Power Pack Assembly

Avenger Parts Manual

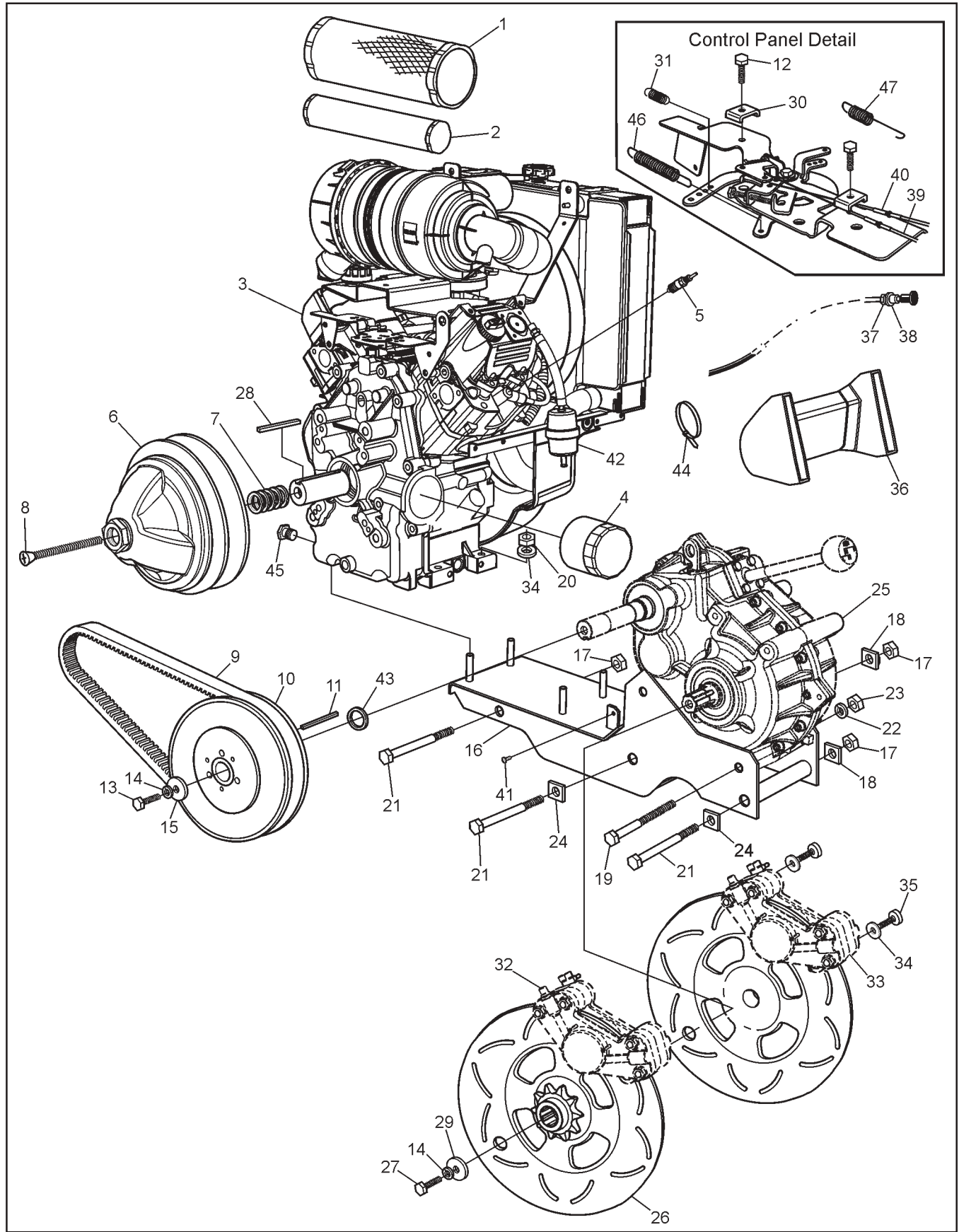

Avenger Parts Manual

4.0 Power Pack Assembly

Ref.	Qty.	Part #	Description
1	1	25 083 01	Filter, Air
2	1	25 083 04	Element, Inner
3	1	LH 690	Kohler 26 HP Engine
4	1	120 50 01	Filter, Oil
5		66 132 01	Sparkplug
6			See Section 3.0 Clutch System
7	5	114-04	Washer, Shim 1.19x1.50x.04
8	1	112-152	FHSC, 7/16-20 x 4.0" LG
9	1	127-137	Drive Belt - 10.5" Cen. Dist
10			See Section 3.0 Clutch System
11	1	110-09	Key 1/4 x 1/4 x 30
12	1	M-545016-S	Screw, Clamp Cable (Kohler #)
13	1	103-34	HHCS 3/8-16 x 1.25 Gr5 Zn
14	3	108-06	Lockwasher 3/8 Split Ring Zn
15	1	108-46	Washer .40 x 1.37 x 1.2 Hi-Carbon
16	1	806-35	Frame Ass'y - Power Pack
17	3	117-09	Locknut, Nylon 5/8-11 Zn
18	2	811-09	Washer, Square - .64 ID
19	2	103-20	HHCS 1/2-13 x 6.5 Gr5 Zn
20	4	117-29	Locknut, Nylon 3/8-16 Zn
21	3	112-58	HHCS 5/8-11 x 7.5 Gr5 Zn
22	2	108-07	Lockwasher 1/2 Split Ring Zn
23	2	117-06	Nut, Fin Hex 1/2-13 Zn
24	2	811-15	Washer, Square Lock .64 ID
25			See Section 1.0 Transmission
26	2	606-74	Disc, Brake-Splined #60-10T
27	2	103-18	HHCS 3/8-24 x 1.25 Gr5 Zn
28	1	110-18	Key 1/4 x 1/4 x 1.75
29	2	108-18	Washer .40 x 1.37 x .12 Zn
30	1	12 237 01-S	Clamp, Cable (Kohler #)
31	1	24 089 51-S	Spring, Throttle (Kohler #)
32			See Section 5.0 Steering & Brake System
33			See Section 5.0 Steering & Brake System

Ref.	Qty.	Part #	Description
34	8	108-23	Washer .42 x .81 x .06 Gr8 Zn
35	4	103-41	SHCS 3/8-16 x 1.25 Zn
36			See Section 2.0 Intake & Exhaust
37	1	117-68	Nut, Jam 3/8-24 UNF Zn
38	1	108-32	Lockwasher 3/8 Int. Tooth
39	1	612-92	Cable Ass'y, Choke
40	1	612-116	Cable Asm., Throttle – Avenger
41	2	103-71	Screw, IHWHT/C 1/4-20 x 1.25 Zn
42	1	125-64	Filter, Fuel
43	as req	108-36	Washer, 1.03 x 1.37 x .06 Zn
44	2	100-102	Tie Wrap - 14" - White
45	1	112-156	Plug, Oil Drain 3/8-18NPT Hex
46	1	24 089 46-S	Spring, Governer (Kohler #)
47	1	127-49	Spring, Extension

5.0 Steering & Brake System

Avenger Parts Manual

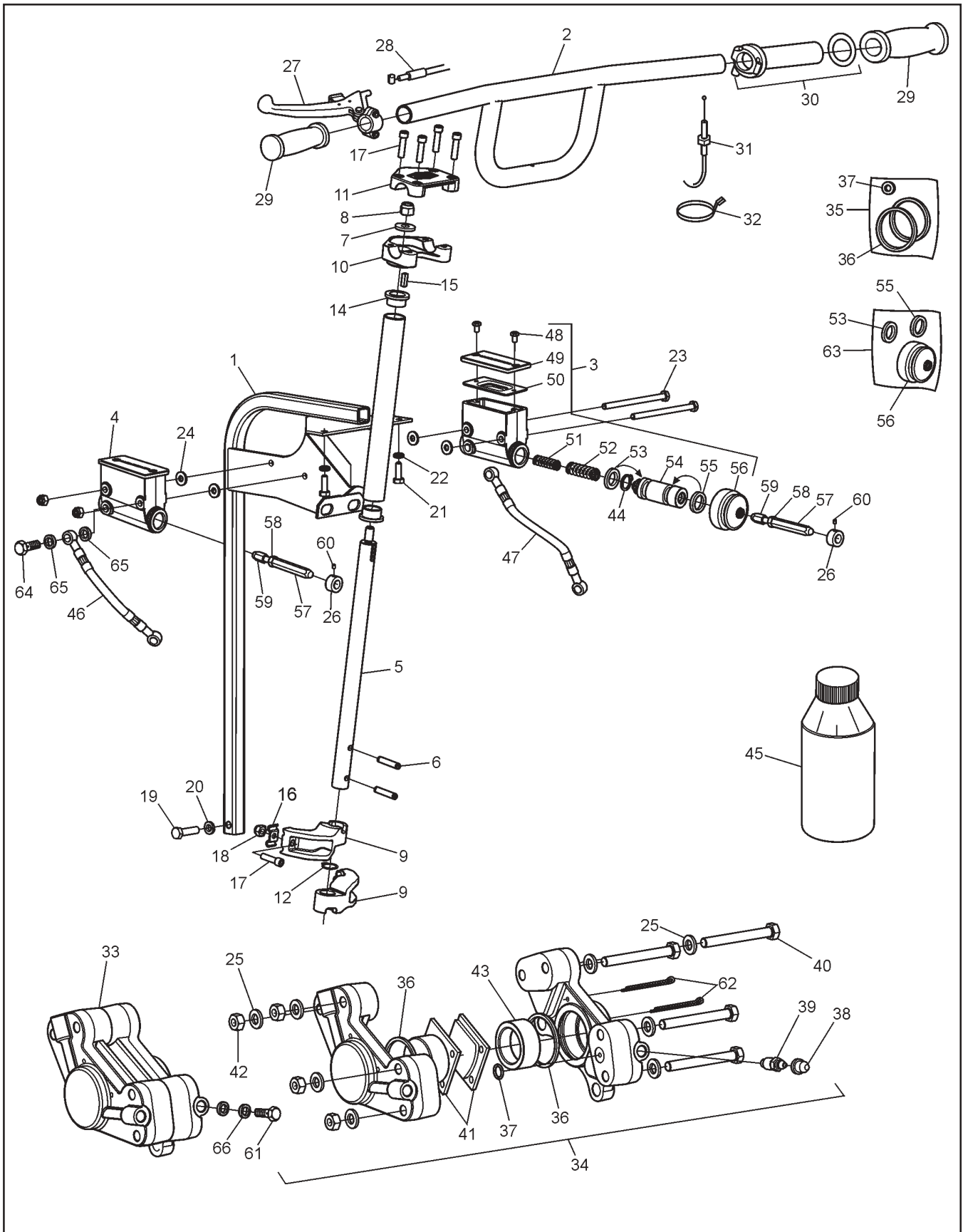

Avenger Parts Manual

5.0 Steering & Brake System

Ref.	Qty.	Part #	Description	Ref.	Qty.	Part #	Description
1	1	612-123	Frame Assembly, Steering Column	41	1	170-03	Pad Set (4), Brake - Non-Asbestos
2	1	612-107	Handlebar Assembly	42	2x4	117-03	Nut, Fin Hex 5/16-18 Zn
3	1	165-13	Master Cylinder - R	43	2x2	168-01	Piston, Knott Caliper
4	1	165-12	Master Cylinder - L	44	1	107-13	Ring, Retaining E-43
5	1	612-122	Shaft, Steering - Argo	45		126-19	Fluid, Brake-Silicon Dot 5 - .35L
6	2	104-42	Pin, Spring 1/4 x 1.5"	46	1	163-03	Hose Asm, Hydraulic - Left - Avenger
7	1	108-47	Washer, .39 x .94 x .13 Zn Di-chr	47	1	163-04	Hose Asm, Hydraulic - Right - Avenger
8	1	117-29	Locknut, Nylon 3/8-16 Zn	48	2x2	103-47	HHMS #10-24 x 1/2" Zn
9	2	612-124	Arm, Steering	49	2x1	168-17	Cover
10	1	612-106	Clamp, Lower Handlebar	50	2x1	168-16	Cover, Rubber
11	1	612-105	Clamp, Upper Handlebar	51	2x1	162-06	Spring, Comp. 12.7 x 49.3mm
12	1	106-07	Ring, Retaining SH-0075PA	52	2x1	162-07	Spring, Comp. 17.3 x 49.3mm
14	2	105-16	Bushing, Oilite - 3/4 x 1/2	53	2x1		Seal, Primary, 19mm (See Ref. 63)
15	1	110-17	Key, 3/16 x 3/16 x .625	54	2x1	168-18	Piston 19mm dia.
16	2	128-10	Retainer, Handbrake Cable	55	2x1		Seal, Secondary, 19mm (See Ref. 63)
17	6	112-47	SHCS, 1/4-20 x 1.0 Zn	56	2x1		Boot, Rubber (See Ref. 63)
18	4	117-27	Locknut, Nylon 1/4-20 Zn	57	2	812-30	Pin, Female
19	1	103-38	HHCS 5/16-18 x 1.25 Gr5 Zn	58	2	117-03	Nut, Fin Hex 1/4-20 Zn
20	1	108-05	Lockwasher 5/16 Split-Ring Zn	59	2	812-31	Fin, Male
21	2	112-04	HHCS 1/4-20 x 3/4 Gr2 Zn	60	2	112-02	SHSS 10-24x1/4 Knurl Cup PT, PL
22	2	108-17	Lockwasher 1/4 Int Tooth Zn	61	2	160-45	Bolt, Banjo
23	2	103-66	HHCS, 1/4-20 x 4.0 Gr5 Zn	62	2x2	168-07	Pin, Cotter 1/8 x 3.00 Zn
24	4	108-08	Washer, .28 x .62 x .04 Zn	63	2x1	161-06	O-Ring Kit - Master Cylinder (incl. Ref. 53, 55 & 56)
25	2x8	108-24	Washer, .34 x .70 x .06 Zn	64	2	160-44	Bolt, Banjo - M10 x 1,0 x 21,0
26	2	812-17	Collar	65	4	160-01	Washer, Copper - 1,5 x 10,0 x 14,0
27	1	128-08	Lever Assembly, Handbrake	66	4	160-04	Washer, Copper 2.3 x 10.0 x 16.0
28	1	128-09	Cable Assembly, Handbrake				
29	2	127-35	Grip, Molded				
30	1	127-81	Throttle Twist Grip				
31	1	612-116	Cable Asm., Throttle - Avenger				
32	1	100-64	Tie Wrap - 5.5"- Black				
33	1	166-10	Caliper, Hydraulic Brake - L w/o pads				
34	1	166-11	Caliper, Hydraulic Brake - R w/o pads				
35	2	161-05	O-ring Kit, Knott Caliper				
36	2		Seal, Piston				
37	2		Seal, Rubber				
38	2x1	168-20	Plug, Rubber				
39	2x1	168-02	Screw, Bleeding, Knott Caliper				
40	2x4	112-154	SHCS, 5/16-18 x 2.75 Zn				

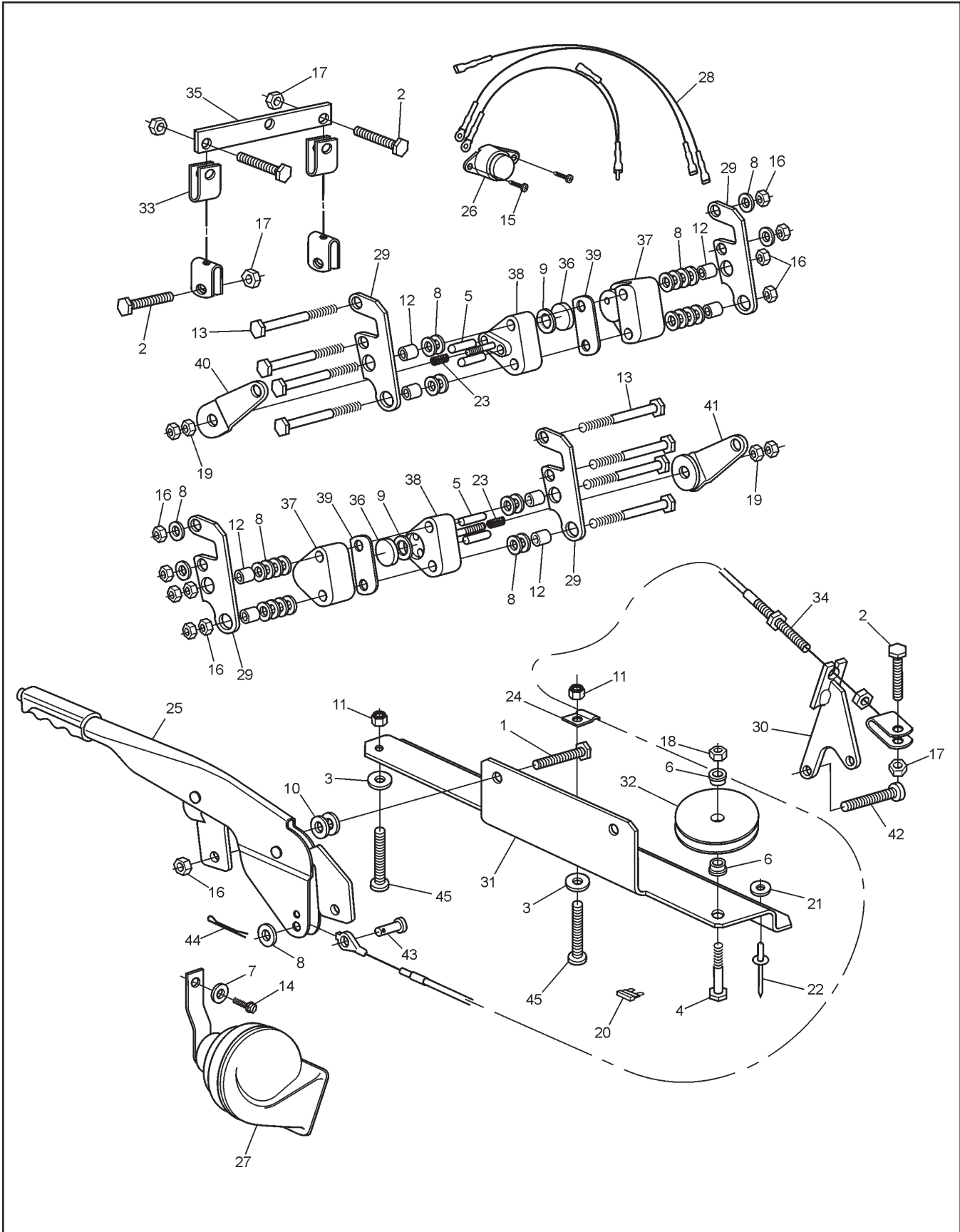

Ref.	Qty.	Part #	Description
1	2	103-06	HHCS 5/16-18x1.0 Gr5 Zn
2	5	103-08	HHCS 1/4-20x1.0 Zn
3	2	108-42	Washer .21x1.0x.06 Zn
4	1	103-82	HHCS 3/8-16x1.5 Gr5 Zn
5	4	104-41	Pin, Rounded Dowel 5/16x1
6	2	105-18	Bushing, Oilite - 3/8x1/4
7	2	108-08	Washer .28x.62x.07 Zn
8	12	108-24	Washer .34x.70x.06 Zn
9	2	108-35	Washer .53x1.06x.09 Zn
10	4	108-47	Washer .39x.94x.13 Zn Di-Chro
11	2	117-10	Locknut, 10-24 N/I Zn
12	8	108-71	Spacer-5/16 IDx7/16 ODx13/32 L
13	8	112-132	HHCS 5/16-18 x 3.25 Gr5 Zn
14	1	112-19	Screw,IHWH T/C Slot 1/4-20x1/2
15	2	112-56	T/S Pan Head Phil #10x3/4 A Zn
16	6	117-21	Locknut, Nylon 5/16-18 Zn
17	5	117-27	Locknut, Nylon 1/4-20 Zn
18	1	117-29	Locknut, Nylon 3/8-16 Zn
19	4	117-46	Locknut, 2-way 5/16-24 Zn
20	1	118-52	Fuse, 10A 2-Prong (AT010)
21	4	120-04	Washer .19x.50x.08 Zn
22	4	120-09	Rivet - 3/16 x 1.0 Black
23	2	128-12	Spring, Comp .437 x .62" Lg.
24	1	128-13	Clip, Conduit-Anti
25	1	809-147	Lever, Parking Brake
26	1	848-86	Button, Horn
27	1	848-87	Horn, Electric
28	1	848-88	Wire Harness, Horn
29	4	850-71	Bracket, Mechanical Brake
30	1	850-72	Bracket Asm, Parking/Brake
31	1	850-78	Bracket, Parking Lever
32	1	850-79	Pulley, Parking Brake Cable
33	2	850-80	Cable, Parking Brake Equalizer
34	1	850-81	Cable, Parking Brake
35	1	850-82	Flat Bar, Equalizer
36	2	850-83	Puck, Friction
37	2	850-84	Brake Housing, Dead Side
38	2	850-85	Brake Housing, Live Side
39	2	850-87	Plate, Shim
40	1	850-88	Lever Asm, Brake - R
41	1	850-75	Lever Asm, Brake - L
42	1	112-143/PI	SHCS 5/16x1.25 Zn
43	1	104-27	Pin, Clevis 5/16x.75" Zn
44	1	100-100	Pin, Cotter 1/8x3/4 Zn
45	2	112-07	RHMS 10-24 x 1.50 Zn

7.0 Vehicle Body & Firewall

Avenger Parts Manual

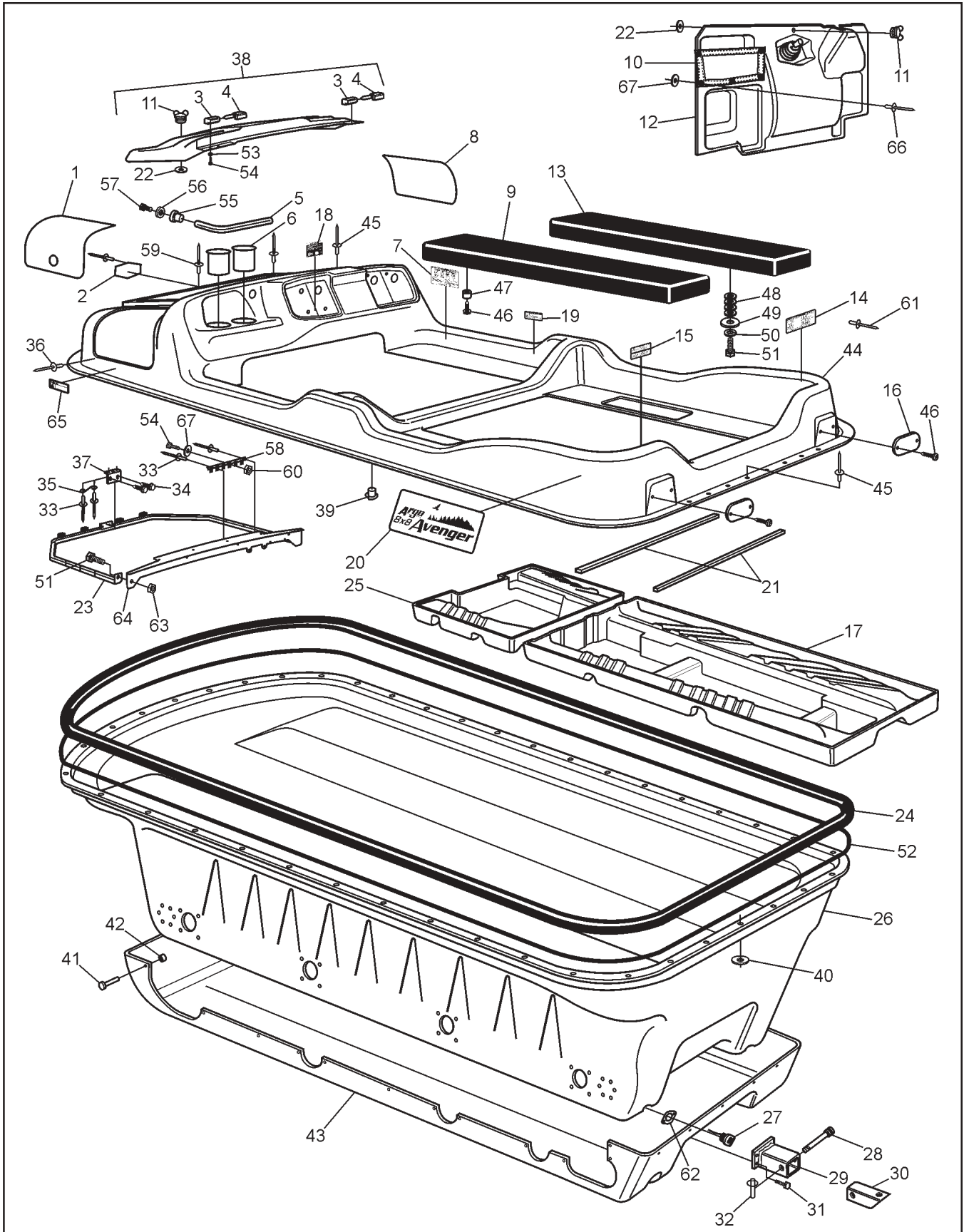

Avenger Parts Manual

7.0 Vehicle Body & Firewall

Ref.	Qty.	Part #	Description	Ref.	Qty.	Part #	Description
1	1	707-43	Screen - Exhaust - Avenger	40	54	120-04	Washer .19 x .50 x .08 Zn
2	1	601-44	Nameplate, "Argo"	41	32	120-27	Pin, Magna Grip
3	2	127-45B	Knuckle, Hinge	42	32	120-28	Collar, Magna Grip
4	2	127-45A	Pin, Hinge	43	1	801-51	Skid Plate, 8x8 - Black
5	1	601-101	Tube, Dash Handle	44	1	801-52	Body & Hood, Upper -
6	2	100-109	Cup holder Insert				Avenger (spec. colour) (incl.
7	1	126-68	Plate, Operation				23, 33, 34, 35, 37, 38)
8	1	707-42	Screen, Intake - Avenger	45	80	120-09	Rivet 3/16 x 1 - Black
9	1	608-64	Seat, Rear - Left	46	8	103-48	T/S Pan HD PHIL #10 x 5/8
10	1	100-108	Mesh, Glove Box	47	4	126-79	Bumper, Plastic - Black
11	2	126-10	Wing Stud	48	16	108-25	Washer .31 x .75 x .06 Zn
12	1	803-60	Firewall, Avenger	49	4	801-41	Washer, Seat
13	1	608-65	Seat, Rear - Right	50	4	108-03	Lockwasher 1/4
14	1	126-67	Plate, Floor Pan	51	6	112-04	HHCS 1/4-20 x 3/4 Gr2 Zn
15	1	127-142	Plate, Vehicle Capacity -	52	1	126-60	Vinyl Strip, 1/2" x 1/4" x 37.5'
			Avenger	53	8	108-59	Lockwasher #10 Int. Tooth Zn
16	2	127-01	Reflector, Red	54	9	103-47	HHCS 10-24 x 1/2
17	1	803-58	Floor Pan, Rear - Avenger	55	1	113-12	Insert, 1/2-13
18	1	127-141	Label, Caution - Keyswitch	56	1	108-35	Washer .53 x 1.06 x .09 Zn
19	1	126-69	Plate, Fuel	57	1	112-151	HHCS 1/2-13 x 1" Gr2 Zn
20	2	127-138	Nameplate - Avenger	58	1	613-37	Terminal Strip, Ground
21	2	601-09	Trim, Vinyl - 28"	59	9	120-13	Rivet, 3/16 x 5/8 Black
22	2	126-09	Grommet, Alum. Flattened	60	1	117-10	Locknut, 10-24 N/I Zn
			Half	61	34	120-24	Rivet, 3/32 x 3/8 Alum. (all
23	1	602-49	Frame Ass'y, Hood - Front				plates)
24	1	801-05	Bumper, Vinyl - 8x8	62	2	100-114	Gasket, Drain Plug
25	1	803-59	Floor Pan, Front - Avenger	63	2	117-82	Locknut, Flange 1/4-20 Zn
26	1	801-50	Body, Lower - Avenger	64	1	602-51	Frame Ass'y, Hood - Rear
27	2	100-107	Plug, Drain - Flanged	65	1	127-144	Label, Warning - HOT
28	1	104-13	Pin, Toplink - 3/4 x 2.75	66	5	120-30	Rivet, 5/32 x .65 Black
29	1	616-16	Hitch Assembly	67	6	120-05	Washer, .19 x .50 x .04 Zn
30	1	616-19	Tube, Hitch				
31	4	103-82	HHCS 3/8-16 x 1.5 Gr5 Zn				
32	1	104-11	Pin, Lynch - Ring				
33	6	120-15	Rivet - 1/8 x 7/16				
34	2	103-72	Screw, IHWH T/C Slot				
			1/4-20x3/4				
35	1	126-11	Spring, Retaining				
36	28	120-11	Rivet 5/32 x 9/16 - Black				
37	1	601-69	Plate, Spring				
38	1	602-47	Hood Kit - Avenger (spec.				
			colour) (incl.3, 4, 11, 22, 53, 54)				
39	2	117-44	T- Nut 1/4-20 Zn				

8.0 Frame and Drive System

Avenger Parts Manual

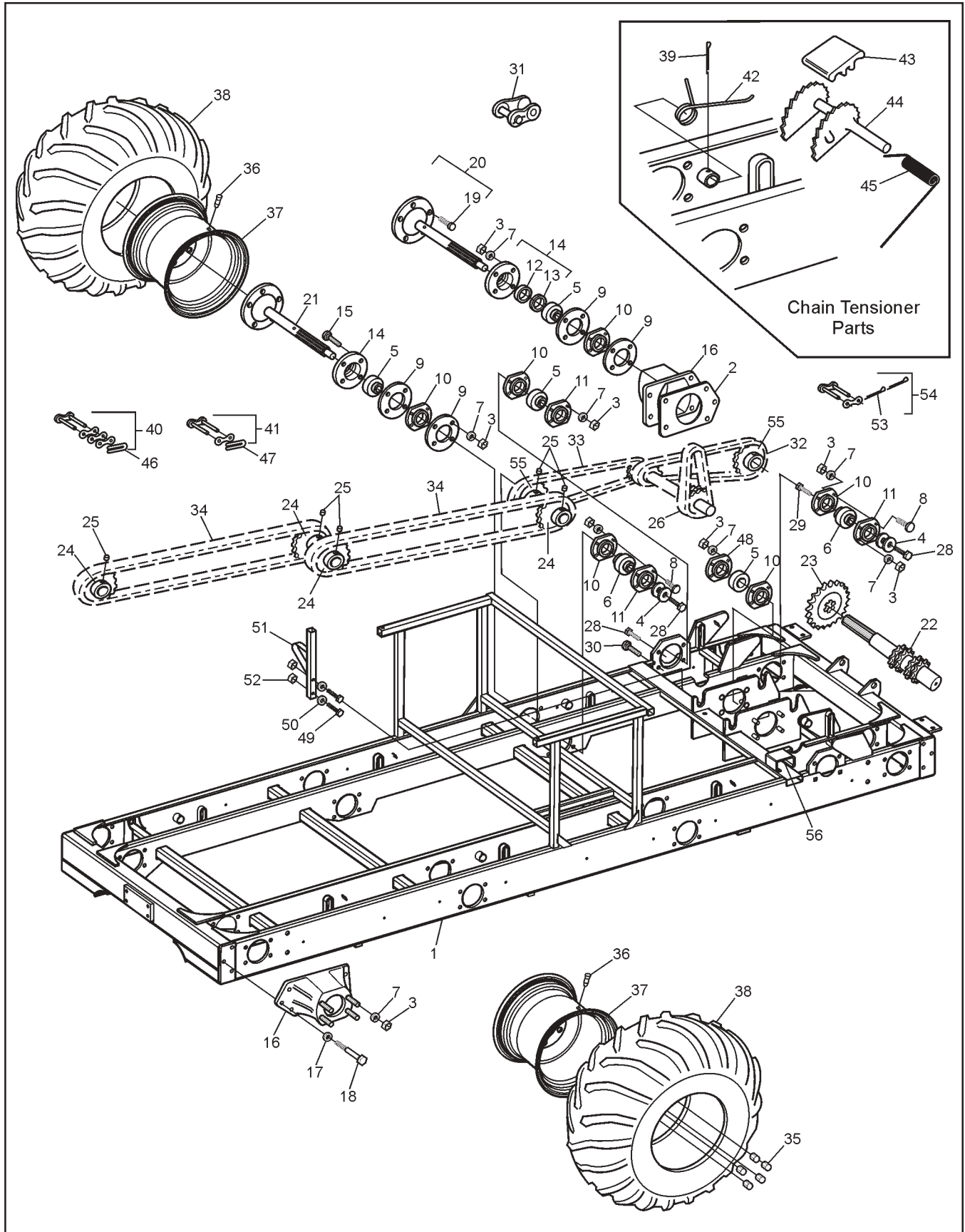

Avenger Parts Manual

8.0 Frame and Drive System

Ref.	Qty.	Part #	Description	Ref.	Qty.	Part #	Description
1	1	806-10	Frame Asm - Avenger	37	8	127-61C	Rim - 10 x 9 - Charcoal
2	4	606-25	Gasket - Bearing Extension	38	8	127-100SA	Tire, Rawhide III 25 x 11.50-9
3	80	117-29	Locknut, Nylon 3/8-16 Zn	39	8	100-01	Pin, Cotter 1/8 x 1.50 Zn
4	16	108-46	Washer .40 x 1.37 x .12 Hi-Carbon	40	1x4	100-96	Con. Link, RC50-2 H.D.
5	12	101-35	Bearing, Ball - 1.25	41	1x4	603-84	Con. Link, RC60-1 H.D.
6	8	101-41	Bearing, Ball - 1.0	42	8	127-65	Spring Torsion - 1.16x0.35
7	82	108-15	Washer, .42 x .81 x .05 Zn	43	8	606-39	Slider Block -1/2" Shaft
8	31	103-88	C/Bolt 3/8-16 x 1.0 Gr5 Zn	44	8	606-35	Tensioner Asm, Chain
9	16	605-89	Gasket, Flange - Outer	45	8	127-64	Spring, Torsion - .76 x 1.9
10	20	605-63	Flange - 4 hole	46	4	603-95	Spring Clip - RC 50 Closed
11	10	101-20	Flange, Greasable - 4 hole	47	6	603-96	Spring Clip - RC 60 Closed
12	8	102-14	Seal, Oil 1.25 x 1.75 x 0.188	48	2	101-80	Flange, Greaseable - 90 Degree
13	8	102-15	Seal, Oil 1.25 x 1.874 x 0.25	49	2	103-97	HHCS 1/4-20 x 1.25
14	8	605-97	Flange Asm, Outer (incl. Refs. 12 & 13)	50	2	108-08	Washer .28 x .62 x .07
15	16	112-39	C/Bolt 3/8-16 x 1.75 Gr5 Zn	51	1	806-43	Support Asm, Firewall
16	4	810-91	Bearing Extension	52	2	117-27	Locknut, Nylon 1/4-20
17	20	108-34	Washer .47 x .94 x .06 Zn	53	4	104-35	Pin, Cotter 2mm x 12mm
18	20	112-150	HHCS 7/16-20 x 1.5 Gr5 Zn	54	2	603-94	Con. Link, RC60-1 Cotter Pin
19	5x8	103-80	Stud, Wheel 7/16-20 x 1.125 #B271	55	4	810-28	Sprocket, Double - 24T
20	4	810-73	Axle Asm - Front/Rear (incl. Ref. 19)	56	2	606-43	Slide, Chain - 2-3/4"
21	4	810-75	Axle Asm - Mid (incl. Ref. 19)				
22	2	810-32	Shaft, Idler - 11T				
23	2	606-72	Sprocket, Idler S60 x 21T				
24	8	606-34	Sprocket, S60 x 19T				
25	10	112-03	SHSS 5/16-18 x 3/8 1/2 DOG, PL				
26	2	803-54	Chain, Idler RC60-1 x 34P (incl. Ref. 55)				
28	12	112-31	HHCS 3/8-16 x 1.0 2B Gr8 Zn				
29	1	103-82	HHCS 3/8-16 x 1.5 Gr5 Zn				
30	4	112-61	C/Bolt 3/8-16 x 1.25 Gr5 Zn				
31		127-80	Link, Half - RC60 - 1 (opt.)				
32	2	803-55	Chain, RC50-2 x 46P-Front (incl. Ref. 40)				
33	2	803-56	Chain, RC50-2 x 74P-Mid (incl. Ref. 40)				
34	4	803-57	Chain, RC60-1 x 90P-Rear (incl. Ref. 41)				
35	5x8	117-35	Nut, Wheel 7/16-20 Zn				
36	8	125-26	Valve, Tire				

Avenger Parts Manual 9.0 Fuel System & Seat Assembly

Ref.	Qty.	Part #	Description
1	8	108-03	Lockwasher 1/4 Split Ring Zn
2	1	608-61	Frame Assembly, Seat
3	4	112-04	HHCS 1/4-20x3/4 Gr2 Zn
4	1	608-52	Tube Assembly, Fuel Pick-up
5	1	608-59	Neck Assembly, Vented Filler
6	1	608-47	Frame Assembly, Backrest
7	1	608-39	Back pad Assembly
8	1	608-44	Tank, Fuel - Argo
9	2	103-77	HHCS, 1/4-28 X 2.0
10	2	117-01	Locknut, Nylon 1/4-28 Zn
11	1	608-54	Toolbox
12	1	127-54P	See Section 9.0 Electrical System
13	1	608-55	Cover, Battery
14	1	608-45	Seat Assembly, Bench
15	1	608-57	Retainer, Seat - Left
16	1	608-58	Retainer, Seat - Right
17	6	702-06	Foam Cushion
18	1	608-56	Strap, Battery
19	19	120-09	Rivet 3/16x1 - Black
20	4	112-79	Clamp, Hose, 1/2" - Black
21	1	608-66	Hose, Fuel - 80"
22	2	120-04	Washer .19 x .50 x .08 Zn
23	2	100-12	Clamp, Gear 2.25" HF-36
24	1	125-94	Hose, Filler
25	10	112-07	RHMS 10-24x1.50 Zn
26	1	126-46	Cap, Fuel
27	1	127-21	Hose, Vent - 86"
28	1	126-50	Male Connector, 1/4"
29	6	126-94	Clamp, Nylon Wire - 1/4"ID
30	10	108-42	Washer .21x1.0x.06 Zn
31	10	117-10	Locknut, Nylon #10-24 Zn
32	1	117-54	Nut, Locking PAL 1/2-20 Zn
33	3	126-93	Clamp, Nylon Wire - 1/2"ID
34	2	120-15	Rivet, 1/8 x 7/16
35	1	126-11	Spring
36	6	112-41	PHMS, Phil 1/4-20 x 1.25 Zn

Ref.	Qty.	Part #	Description
1	1	613-90	Outlet, 12 Volt DC
2	1	126-76	Knob, Light - Black
3	1	108-55	Lockwasher 7/16 Ext. Tooth Zn
4	1	100-62	Switch, Light
5	2	127-108	Key, Molded
6	1	127-107	Bezel - Cover, Nut
7	1	127-106	Nut, Flanged - Plastic
8	1	127-105	Switch - Ignition
9	1	632-15	Hourmeter #85005C-22
10	2	634-10	Light Kit, #06215-00 5/8" Dia.
11	3	118-02	Terminal, Male #76-1251
12	1	633-10	Voltmeter #07583-15 (#830EM)
13	2	118-48	Heat Shrink 2" x 1/2 Dia.
14	3	634-08	Light, Indicator
15	1	634-23	Gauge, Water Temp. - Avenger
16	1	127-55	Cap, Battery Terminal - Red
17	1	127-54	Battery, Exide 45-50
18	2	613-92	Headlamp Ass'y - Oval w/Bezel (incl. items 26 & 36)
19	2	613-37	Terminal Strip, Ground
20	1	613-96	Wire Harness, Kohler 25HP
21	1	613-46	Insulator, Terminal (2 ga.)
22	1	613-94	Wire, Positive Battery
23	1	613-95	Wire, Negative Battery
24	1	681-00	FOB, Key - Floating (not shown)
25	2	127-56	Terminal, Battery Post
26	2	127-46	Bulb, Headlight - Halogen 37W
27	4	103-25	PHMS #10-24x3/4 Zn
28	4	117-10	Locknut, Nylon #10-24 Zn
29	1	118-52	Fuse, 10A 2 Prong (AT010)
30	3	118-49	Fuse, 15A 2 Prong (AT015)
31	1	118-53	Fuse, 20A 2 Prong (AT020)
32	9	118-62	Terminal - Fuse, single
33	1	118-63	Terminal - Fuse, triple
34	1	118-61	Terminal - Fuse, quad
35	2	118-60	Block - Fuse, 8 position (4 fuse)
36	2	613-93	Bezel, Headlamp - Avenger
37	1	127-143	Label, Fuse Panel - B&S

ARGO Products Manufactured by:

Ontario Drive & Gear Limited

220 Bergey Court
New Hamburg, Ontario
Canada N3A 2J5
Phone: (519) 662-2840
Fax: (519) 662-2421

ODG *Dedicated to quality and performance*